

POWER - CHARGE

Electronic Battery Management System: EBMS-100/150/200

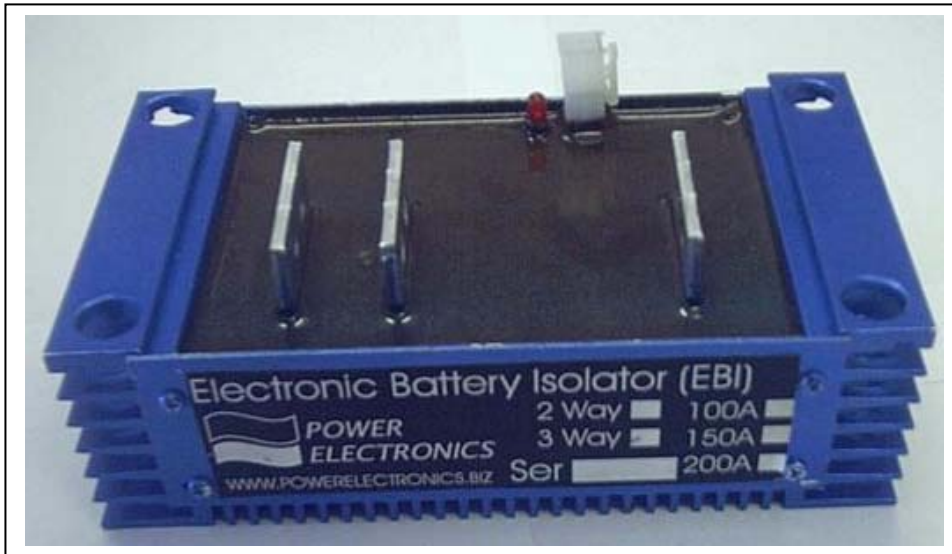

TECHNICAL SPECIFICATIONS:

Working Voltage:..... 10V – 30V
Continuous Current:..... 100 / 150 or 200A
Dimensions (WxDxH): 175 x 100 x 50 mm
Height including connection points = 65mm
Weight:1,15 kg
Thermal cut off switch 125 C

FEATURES:

- Equalizes charge to both batteries
- Ensures both batteries are fully charged
- Direct compatibility to any type of alternator, whether it is equipped with internal or external voltage sensing
- Heavy-duty and waterproof
- Anodized aluminum heat-sink construction
- Optimal battery operation
- Very low voltage drop
- Lower power dissipation
- 2x 6mm connection points for every connector for ease of wiring

The unit incorporates a technically advanced MOSFET/ Schottky Diode - based electronic device that works with both 12V and 24V dual battery systems (**3 way systems also available**). It also has the unique feature of being able to ensure a very low voltage drop between the alternator and the two batteries being charged - to a maximum of 0.6V at rated current. This compares to the almost one volt voltage drop that is common in virtually every other type of diode-based isolators! An internal monitor, but with external control (125C NC thermal switch) is programmed to switch of the alternator in case of any overheating

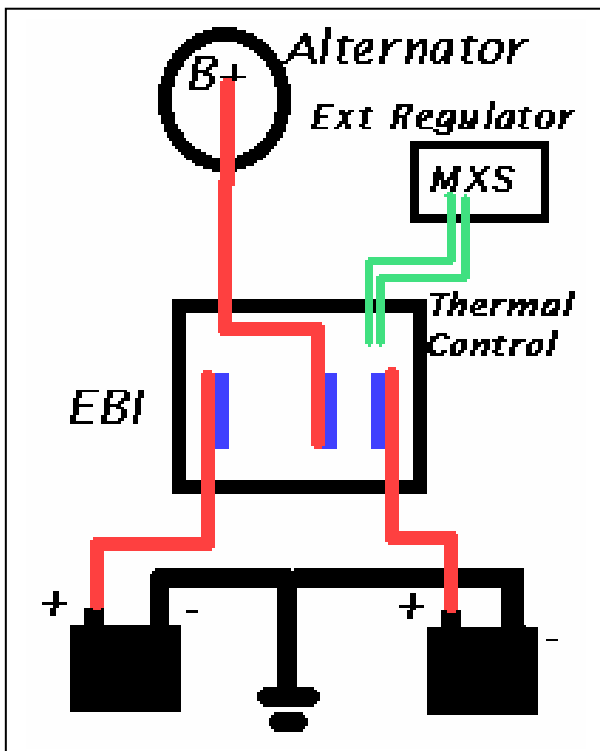

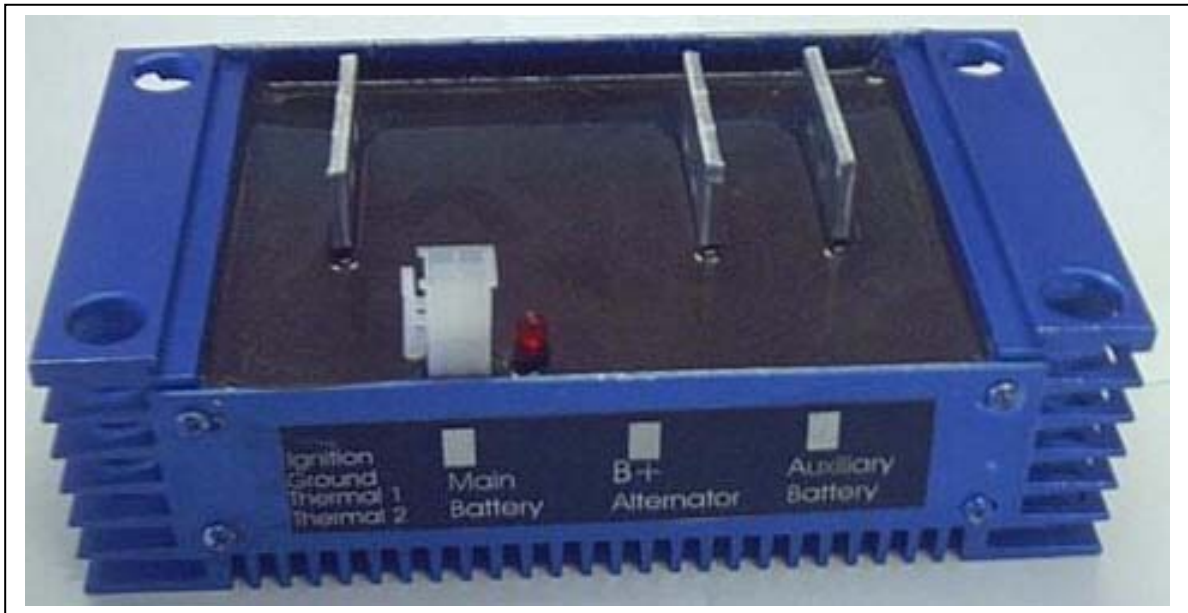
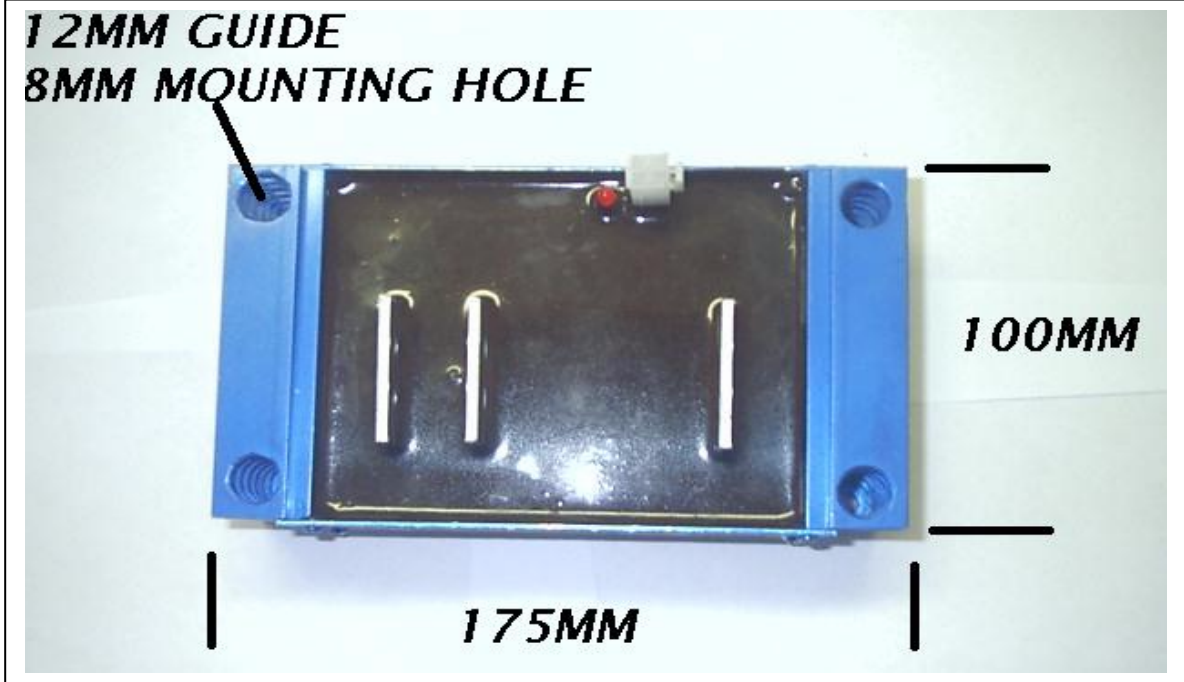

WARRANTY:

12 Month replacement warranty on all parts. Any parts which prove defective within 12 months from date of purchase, will be replaced (Ex factory) FREE OF CHARGE

This warranty is subject to the terms and conditions detailed in the operation and installation manual of this product.

Dealer Information

Another product from:



www.powerelectronics.biz